

型号	ER4-550-SR/U	
种类	水平多关节	
轴数	4	
臂展	550mm(275mm+275mm)	
动作范围	J1	±200°
	J2	±200°
	J3	0-150mm
	J4	±360°
负载	额定值	1kg
	最大值	4kg

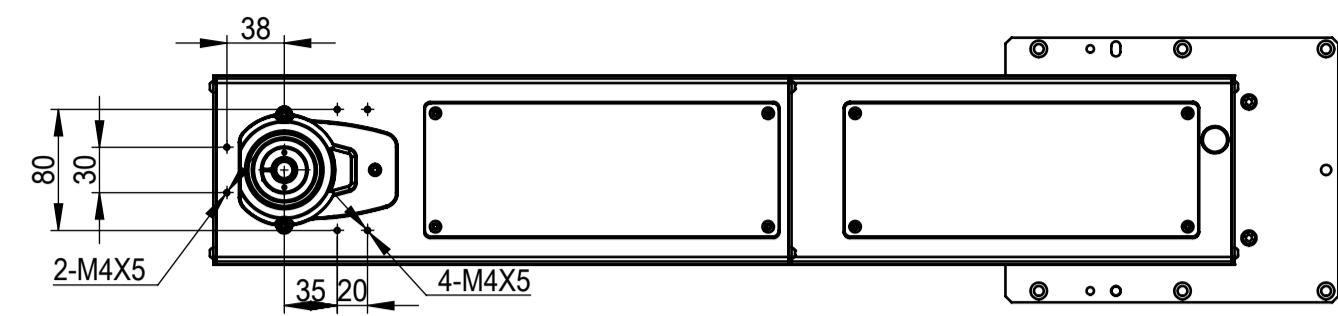

A部详细

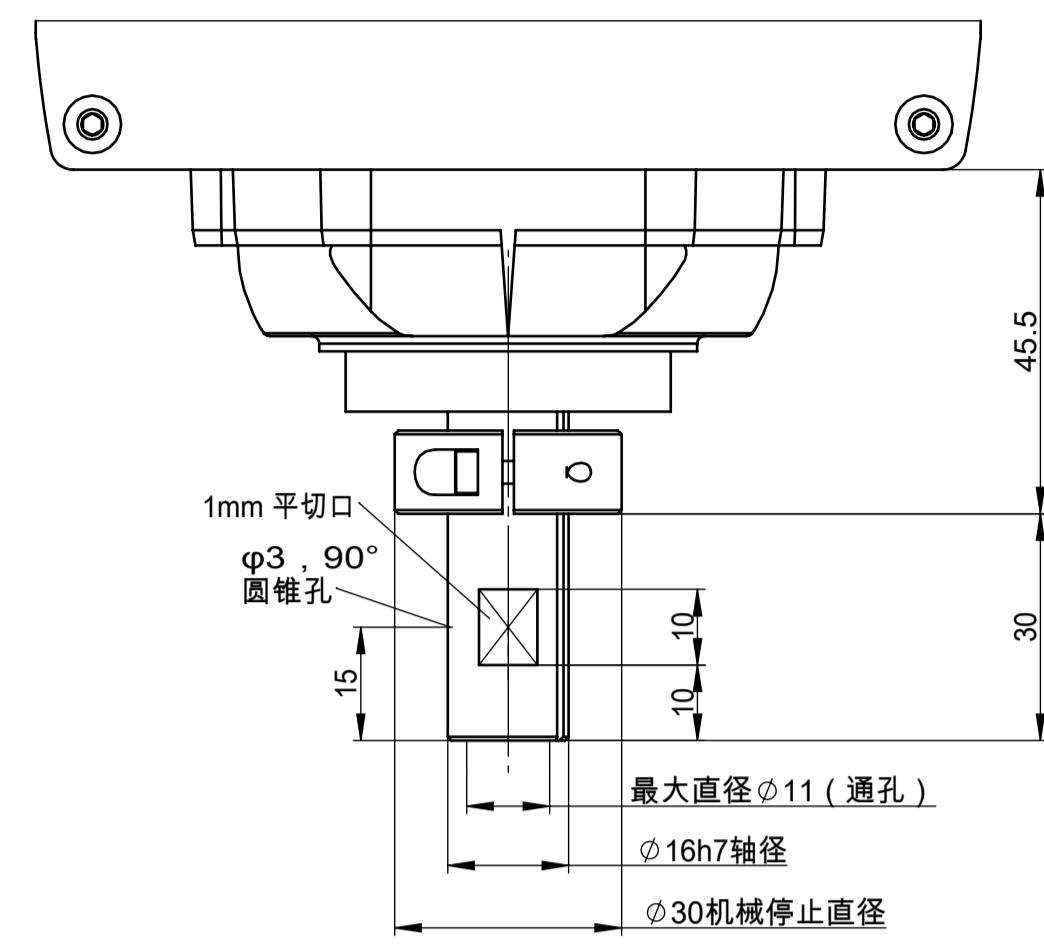

C

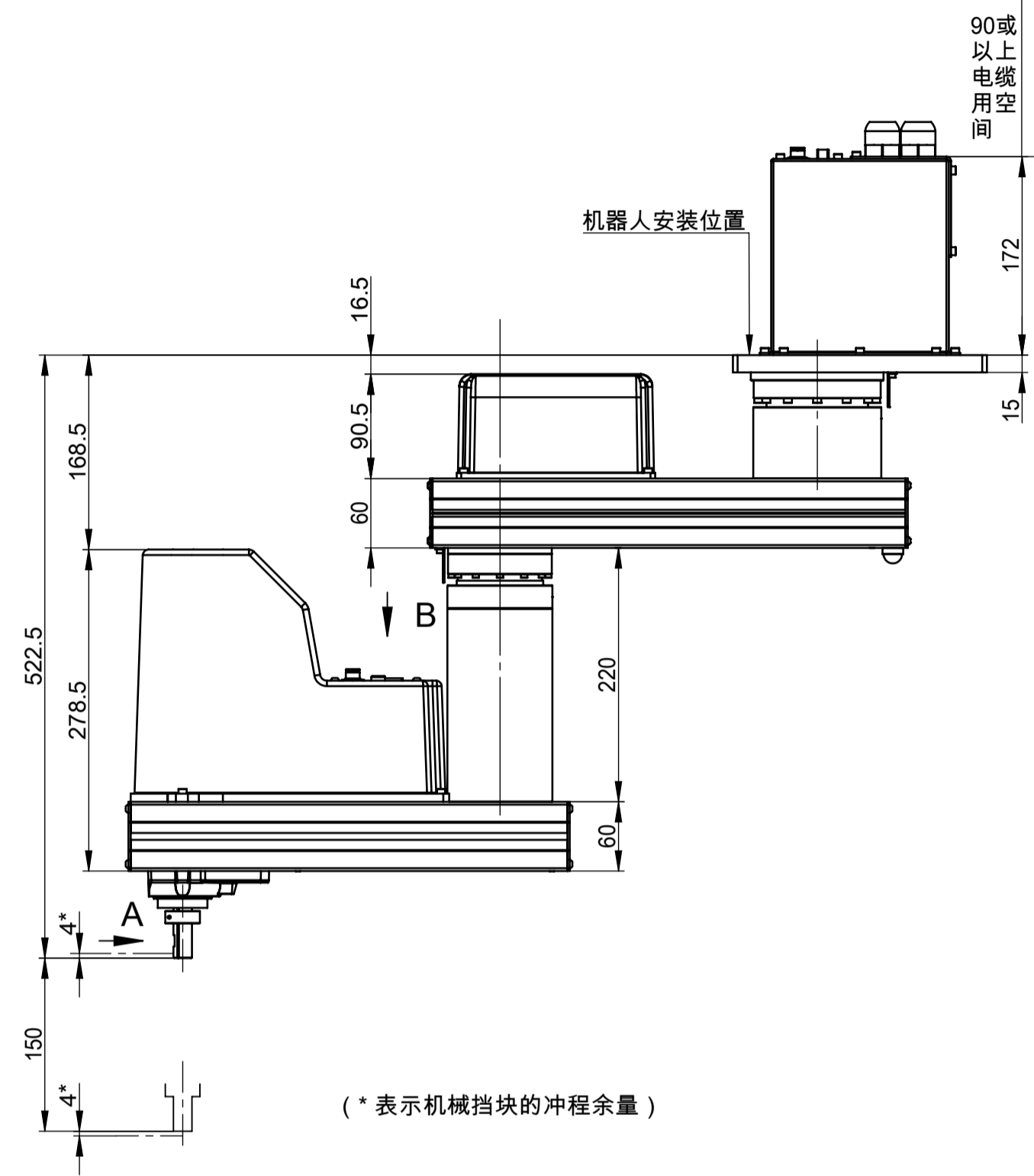

机器人安装位置

90°以上
电缆用空间

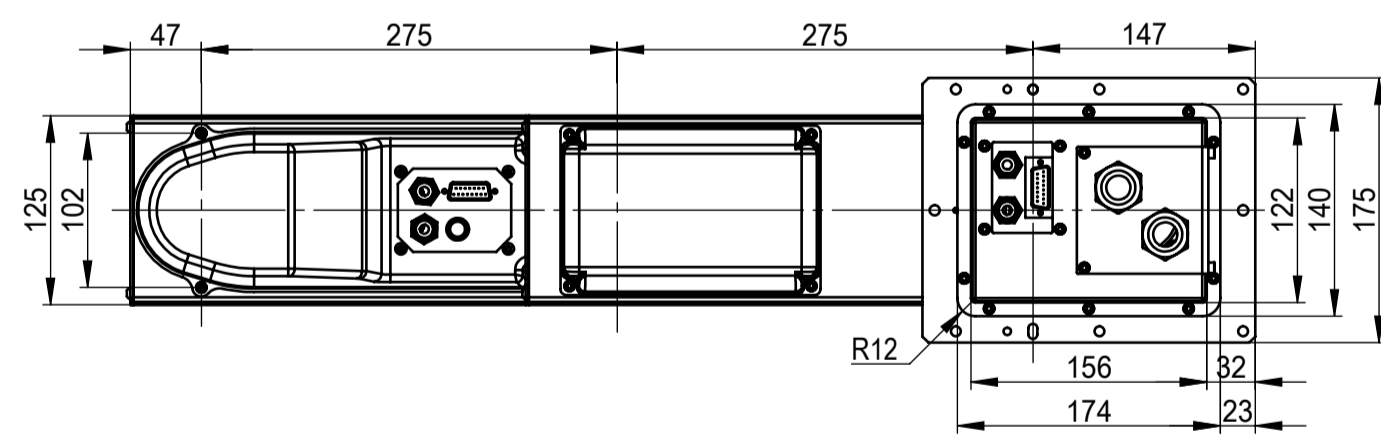
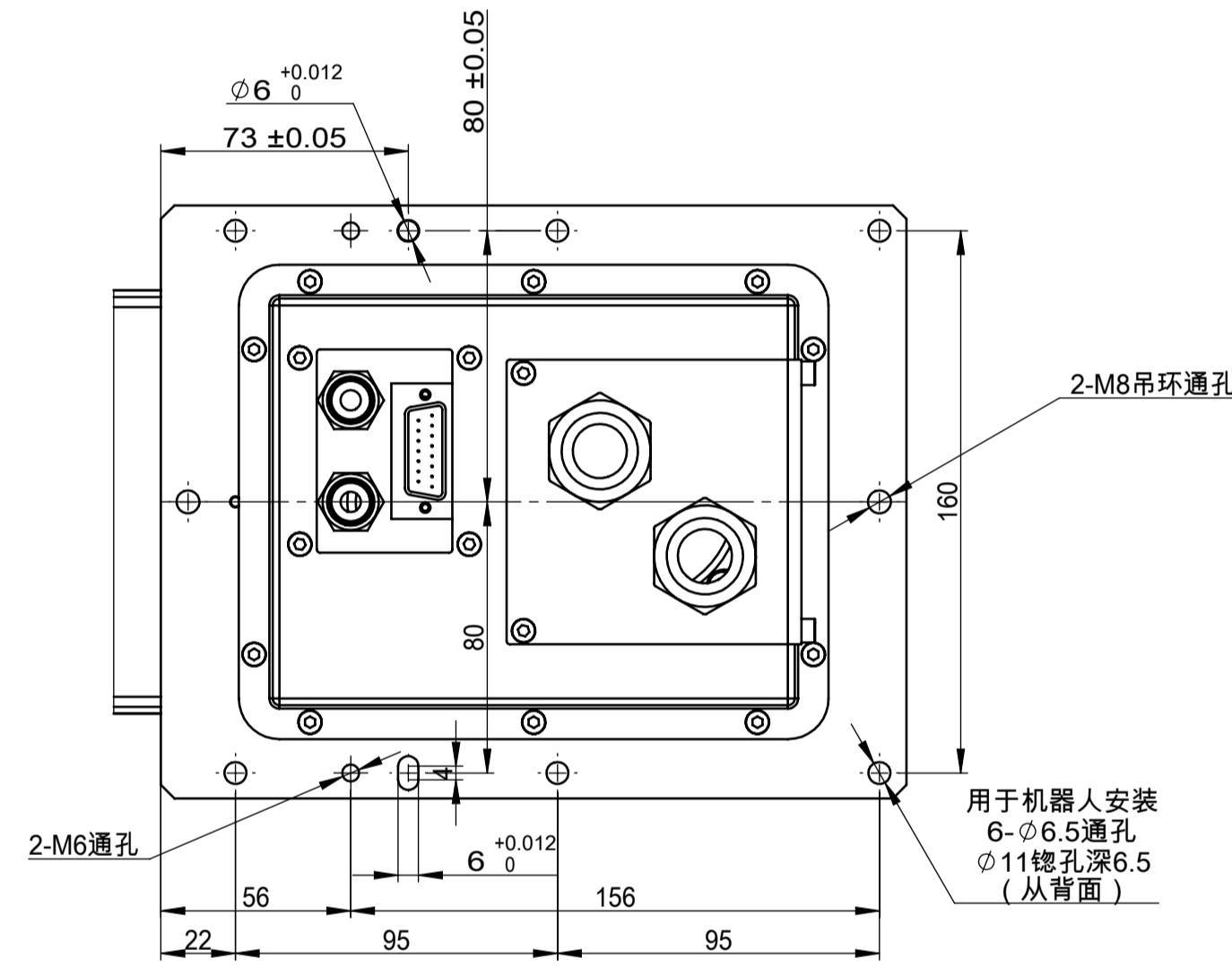
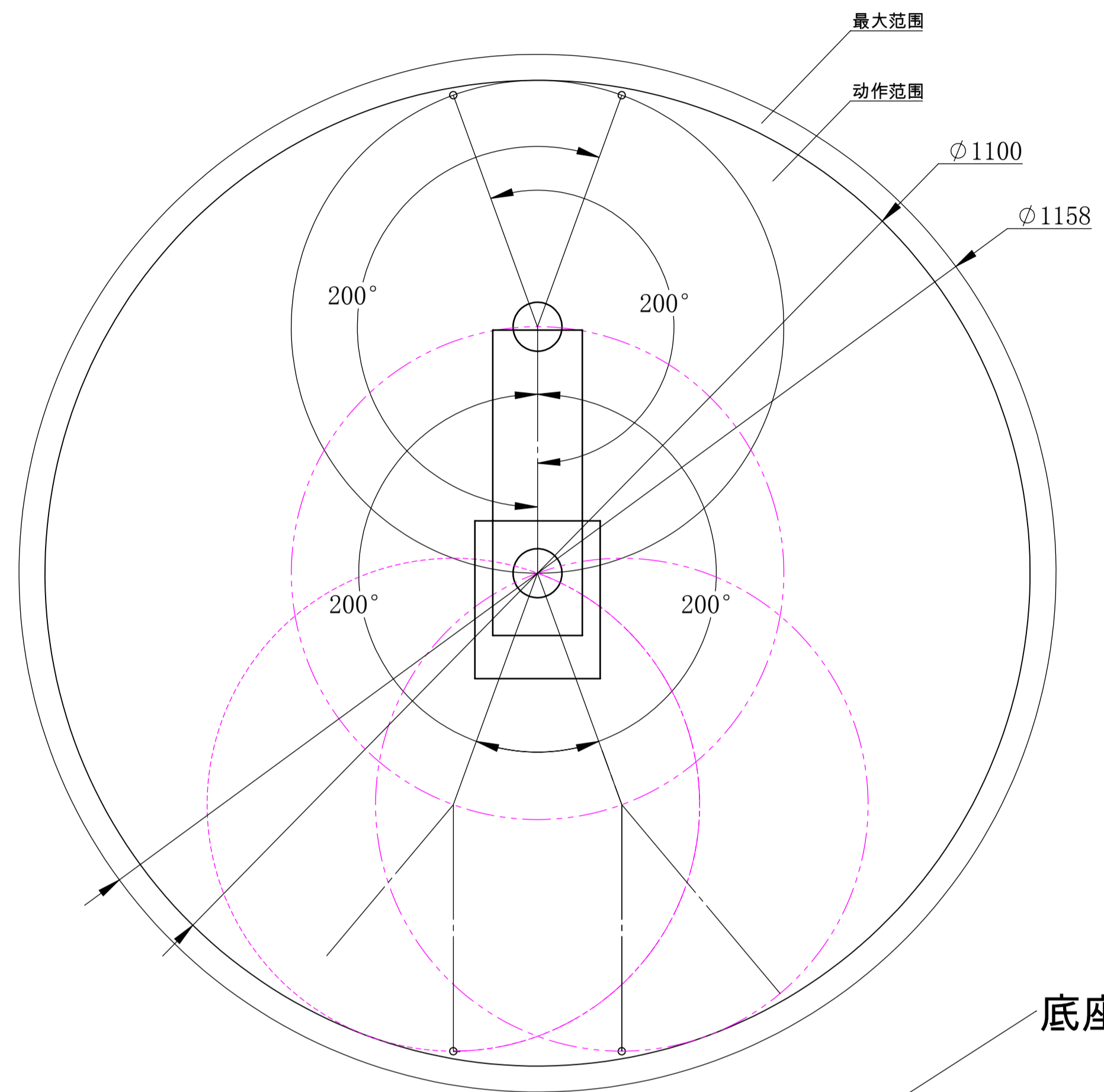

B部视图

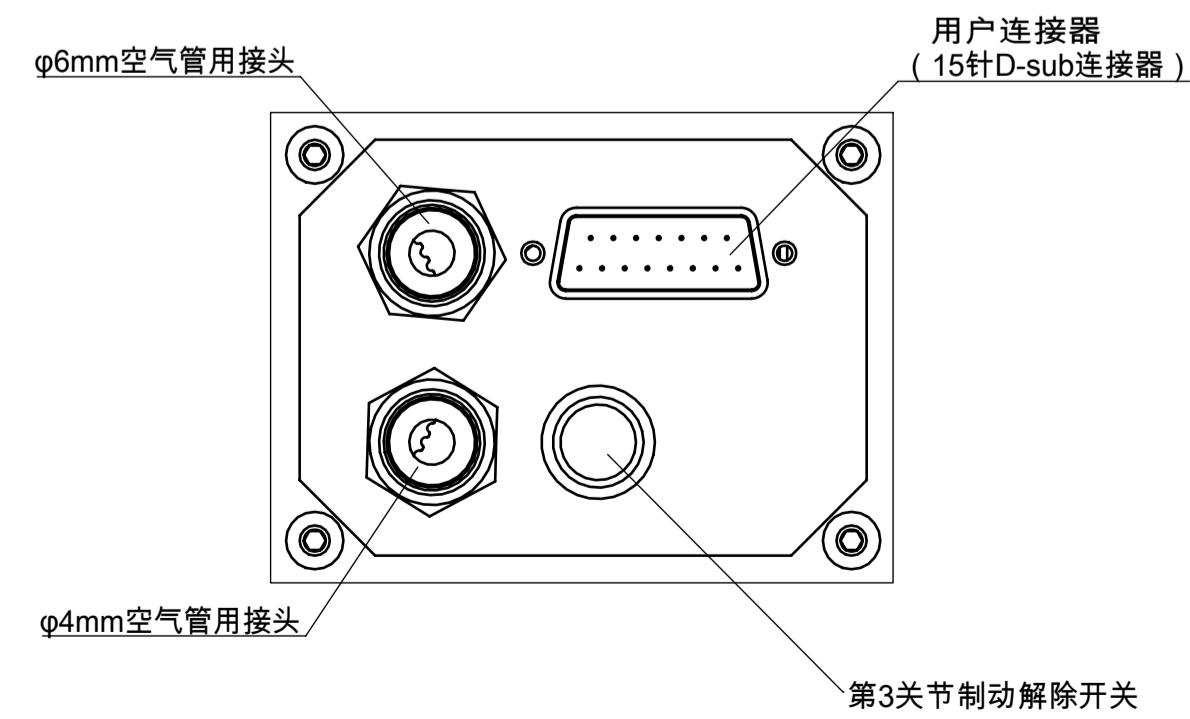

C部视图

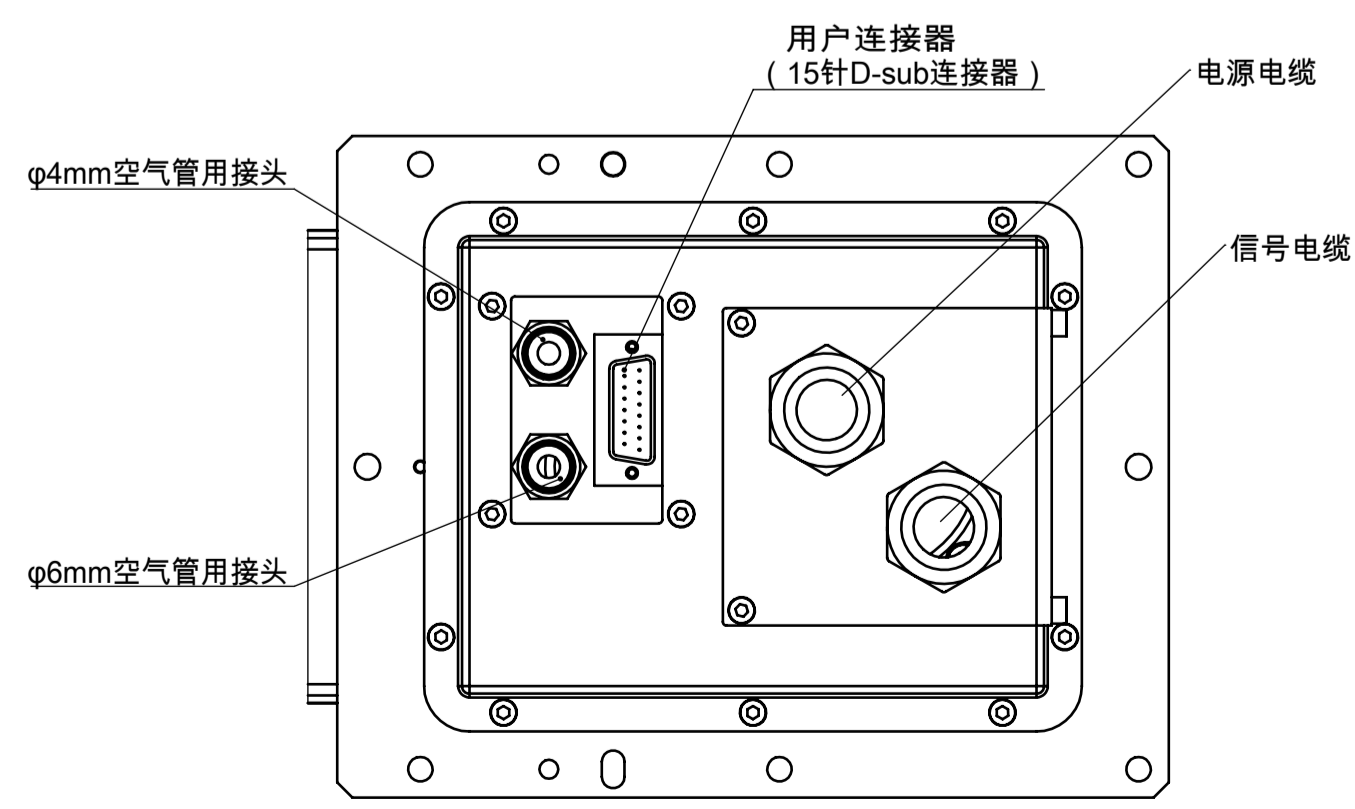

底座安装面

借用件登记
描图
校描
旧底图总号
签字
日期

标记	处数	更改文件号	签字	日期	南京埃斯顿 机器人工程有限公司		
设计							
校对							
工艺							
标准化							
审核					图幅	重量	比例
批准					A1		1:5
					共 1 页	第 1 页	ER4-550-SR/U